

CITY LIVING



1402/2 Chippendale Way Chippendale NSW

1 1 1

Promising lifestyle excellence in the acclaimed 'One Central Park', this stylish studio apartment provides a readymade haven for investors and first home buyers alike. It is placed a stroll to universities, transport, shops and popular dining.

KEY FEATURES

The apartment - Cleverly designed for easy care urban living, the apartment features a sleek stone kitchen with Smeg gas appliances, while a combined living/dining area opens to a sunlit balcony overlooking the complex gardens.

The building - Located in the acclaimed 'One Central Park', residents enjoy access to resort-style facilities including a heated outdoor pool, spa and a professional gym, while there is a 24-hour concierge service and on-site security.

Price : \$ 635,000
Building Size : 44 sqm
View : <https://www.cityliving.com.au/sale/nsw/sydney-city/chippendale/residential/apartment/7223436>



Tasman Fallshaw
02 8248 9104

<https://www.cityliving.com.au>

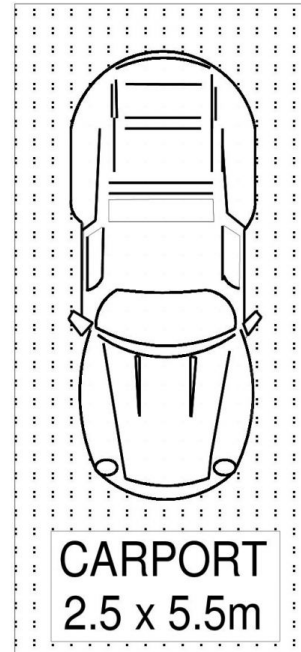
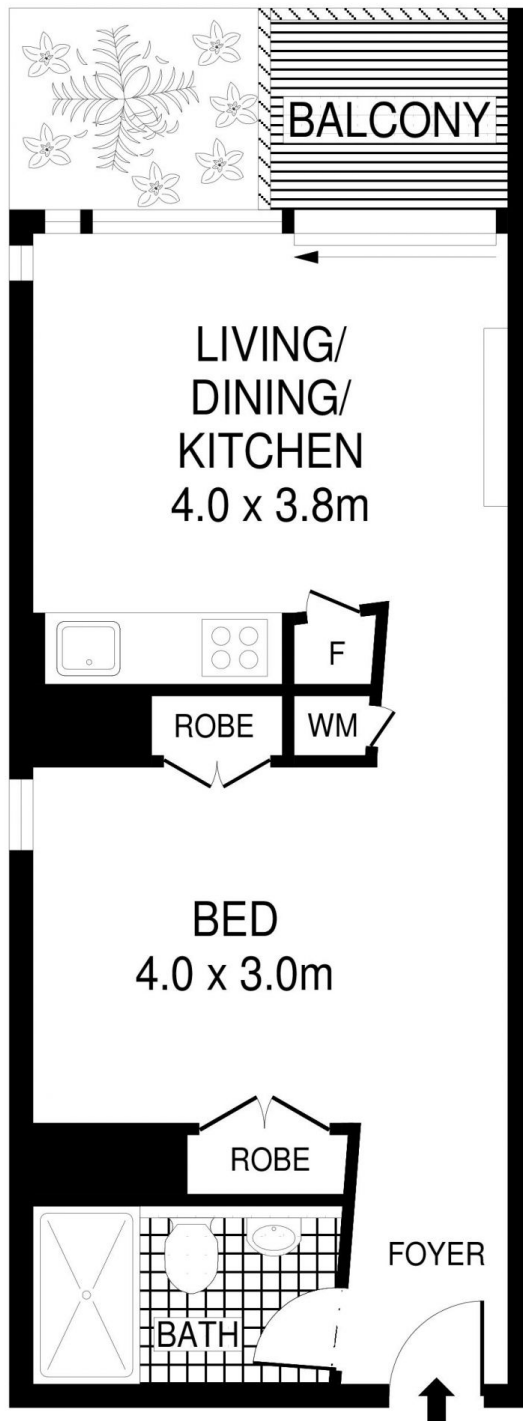

LEVEL FOURTEEN



PLANS SHOWN ONLY INDICATIVE OF LAYOUT. DIMENSIONS ARE APPROXIMATE.
Ref. No: 96422



1402/2 CHIPPENDALE WAY

CHIPPENDALE