

CITY LIVING



21 Hickson Road Walsh Bay NSW

3  2  2 

Presenting this north-facing, three-bedroom apartment set right on the shorefront of Sydney Harbour. This property invites an abundance of natural light and a cool summer breeze. Enjoy this resort style apartment in amidst cafe's, restaurants and only a moments walk to the likes of Barangaroo Reserve and Circular Quay.

Land Size : 153 sqm
View : <https://www.cityliving.com.au/lease/nsw/sydney-city/walsh-bay/residential/apartment/7713059>

KEY FEATURES

The Apartment - Three-bedrooms with built in wardrobes, two bathrooms, master room with ensuite and bathtub. Large granite kitchen with gas cooking and miele appliances, generously sized lounge and dining space with an effortless indoor and outdoor flow through to the balcony, with north facing views over Sydney Harbour, two secure basement parking spaces you wouldn't want to miss your chance to secure this apartment.



Ryan Steele
02 8248 9101



Anthony Kannis
02 8248 9109

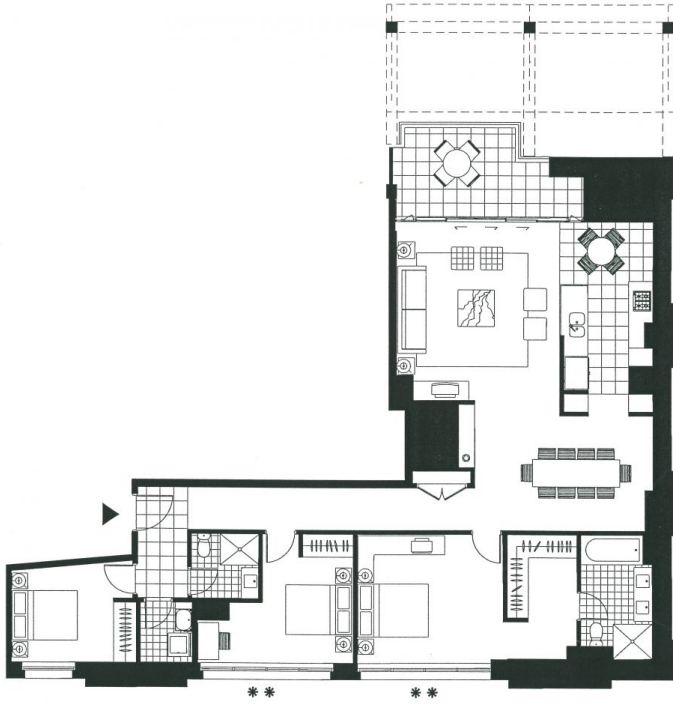

LEVEL 2

** Full height arched feature window

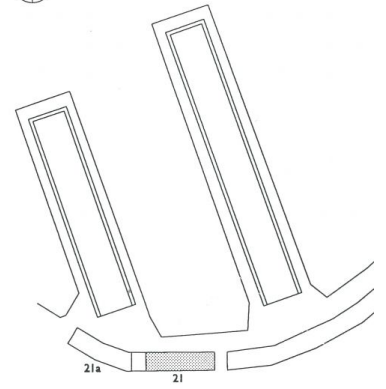

Site Plan

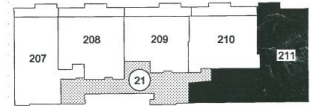

**THE SHORE Apartments
21 Hickson Road**

3 BEDROOM	
Apartment 211	Level 2
Living	4.7 x 5.1m
Dining	5.1 x 3.7m
B'fast	2.6 x 1.8m
Bedroom 1	4.2 x 3.7m
Bedroom 2	3.1 x 3.7m
Bedroom 3	3.6 x 2.7m

NOTE: Room sizes of some bedrooms are taken to back of robe.